

Product Data Sheet

TriplexPro[®]-200 Advanced Plasma Spray Gun

The Sulzer Metco TriplexPro[®]-200 Plasma Spray Gun offers the ultimate in overall performance at power levels up to 100 kW.

The advanced design features of the TriplexPro-200, unavailable on any other thermal spray gun, set new standards of effectiveness, efficiency, economics and environmentally friendly design.

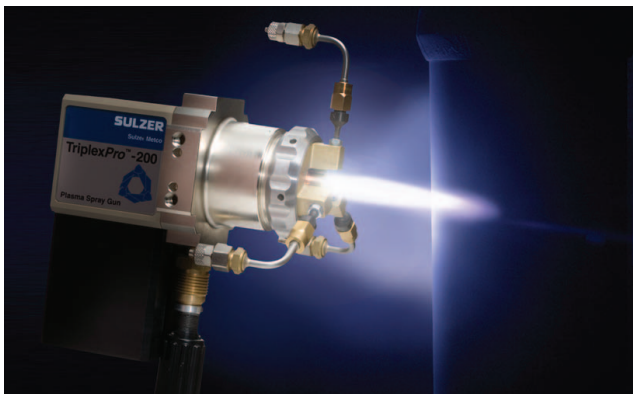

exchanged at designated service intervals, and maintenance is easily performed in house, by the customer.

Environmentally Friendly: Operation of the TriplexPro[®]-200 lowers the use of strategic resources, reduces waste and noise pollution. The high throughput efficiency of TriplexPro-200 significantly reduces the amount of overspray waste produced, and high thermal efficiency lowers overall power consumption. For many applications, excellent coatings are produced using argon-only parameters, eliminating the need for scarce helium gas. With all of this plus the elimination of thoriated tungsten gun components, TriplexPro-200 is the “green gun” of the 21st century.

Effective: TriplexPro[®]-200 produces the widest range of high quality, air plasma coatings in the industry. The unique construction provides performance not achievable with standard plasma guns. The small overall size with right angle hose and cable attachments provides flexibility in terms of the component configurations that can be coated, including internal bores. A variety of spray velocities and plume shapes can be achieved with the selection of available nozzles.

Efficient: TriplexPro[®]-200 saves powder, saves energy and saves time. Efficient heat transfer to the plasma gas and a constant energy state provide the ideal conditions for every powder particle in the plasma stream, improving deposit efficiencies and application rates.

Economical: A smart investment, TriplexPro[®]-200 has the lowest cost per operating hour of any plasma spray gun in the industry. TriplexPro-200 has been validated to maintain constant performance for 200 hours at 62kW with no service intervention, and can be run continuously for up to 16 shifts with little to no process drift or degradation of coating quality. Consumable parts are quickly

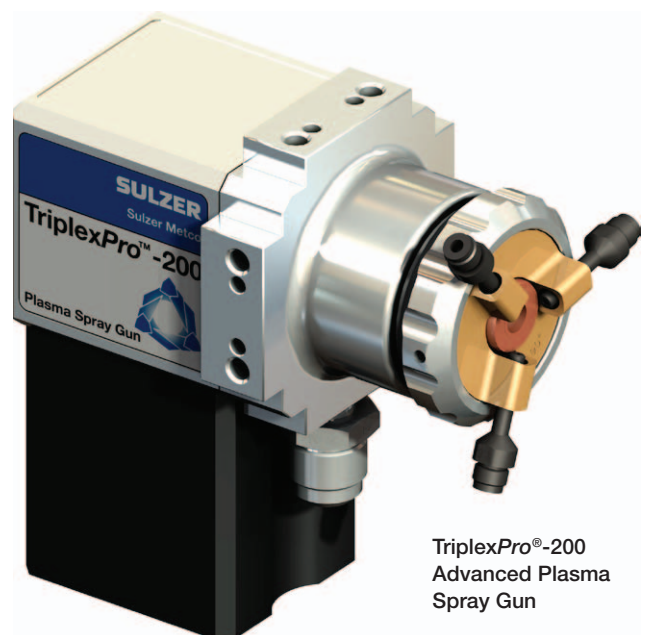

TriplexPro[®]-200
Advanced Plasma
Spray Gun

1 General Description

The TriplexPro®-200 is a universal, all-purpose plasma gun that incorporates three essential design elements:

- Cascaded arc chamber
- Divided arc current
- Standard, exchangeable nozzles

Together, these features make the TriplexPro-200 the most versatile gun on the market today.

1.1 Cascaded Arc Control

Sulzer Metco pioneered the cascaded approach to control and stabilization of arc voltage with the introduction of the APG plasma gun over 20 years ago. Sulzer Metco has refined and enhanced this fundamental technology in the design of the TriplexPro-200.

The key benefits of a cascade gun design are:

- Higher voltage, lower amperage operation
- A magnitude of reduction in oscillation
- The influence of gas flow and type on the arc behavior is eliminated

The cascade fixes the length of the electric arc and provides the arc with a starting path over a series of electrically neutral rings (neutrodes) within the arc chamber. Once the gun is ignited, only the common front anode (nozzle) is electrically connected to the power supply.

The fixed arc length has the advantage of stabilizing the plasma plume, eliminating the very high amplitude power oscillations in the three to five kHz range inherent in plasma guns without arc stabilization. This effect is often overlooked as modern plasma controllers display filtered readings of the actual power and voltage signals from the gun. Thus, for plasma guns without arc stabi-

1.2 Divided Arc Current

The TriplexPro-200 divides the total current equally between three electrodes, a feature first introduced by Sulzer Metco in the late 1980's, which provides the key benefits of improved gun component life and coating processing rates through:

- Uniform heating of the plasma gas
- Less erosion of the anode at arc attachment points
- Defines the location of arc attachments

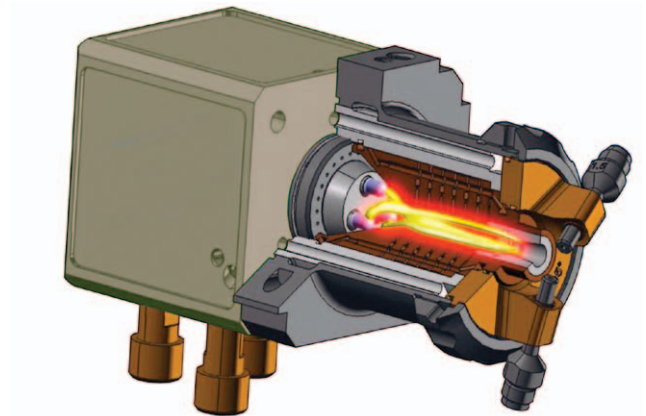

TripLexPro®-200 Cascaded Arc Design

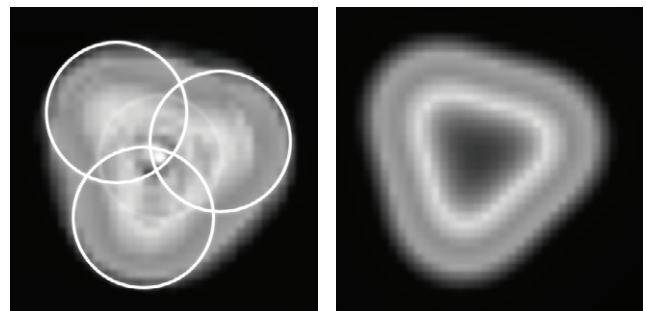

These reconstructed emissivity distributions show the ideal plasma geometry inherent with the TripLexPro-200. Left: in a plasma jet cross-section. Right: using an analytic model of 3 gaussian profiles.

lization, a plasma parameter that is displayed as 65 V actually oscillates between approximately 20 to 85 V. As the amplitude and frequency of the oscillation is directly linked to the heating and flight path of each powder particle, the stable plume produced by the TriplexPro-200 significantly increases deposit efficiency and the consistent quality of the coating.

Three arcs operating at a higher overall voltage has the advantage of stable gun operation over periods of time. For example, a 200-hour endurance test of the TripLexPro-200 at 62kw, with coating samples of chrome oxide periodically sprayed and evaluated, produced the following results:

- Voltage remained within ± 1 V of set point
- Individual electrode weight loss was less than 0.06 g (0.0021 ounces)
- All coating samples demonstrated highly consistent coating quality and microstructure.

The three-arc arrangement is a key performance element of the TriplexPro-200. Studies of conventional plasma gun nozzles often show that the arc creates a wear pattern on one side of the anode bore. The relationship of the arc attachment relative to the radial position of the injector has, in some cases, a large effect on overall gun performance. The three arcs of the TriplexPro-200 have a magnetic repulsion separation of 120 degrees, which generate a symmetrical plume with defined zones of preferred powder injection.

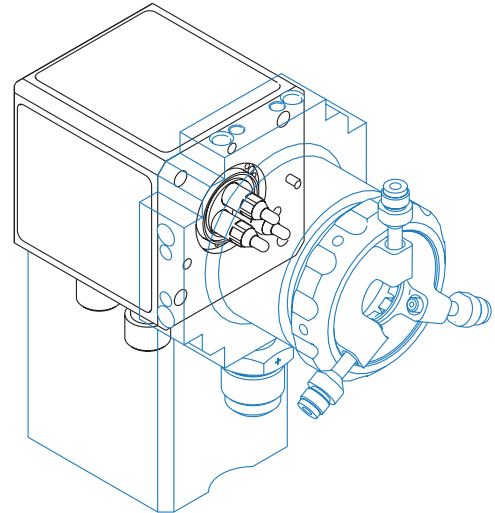

1.3 Exchangeable Nozzles

The TriplexPro®-200 is supplied with the following nozzles, injectors and injector holders to maximize the usable range of the gun:

Qty.	Description	Application
1	Nozzle 9 mm Standard	Ceramics, abrasives
1	Nozzle 6.5 mm	Alloys, selected ceramics
1	Nozzle 5 mm High velocity	Carbides
3	Injector holder	105° long, 90° long, 90° short
1	Powder injector 1.8 mm Standard	
1	Powder injector 2 mm	

Each nozzle is designed for a specific function and is easily exchanged within minutes. Sulzer Metco has leveraged the design freedom that results from the unique arc control design of the gun to offer nozzles that cover the normal parameters associated with plasma spray as well as extend the range of the gun into new unique operational ranges.



TriplexPro®-200 • Divided Arc Current Design



The unprecedented operational scope of TriplexPro®-200 will expand the range of plasma spray applications

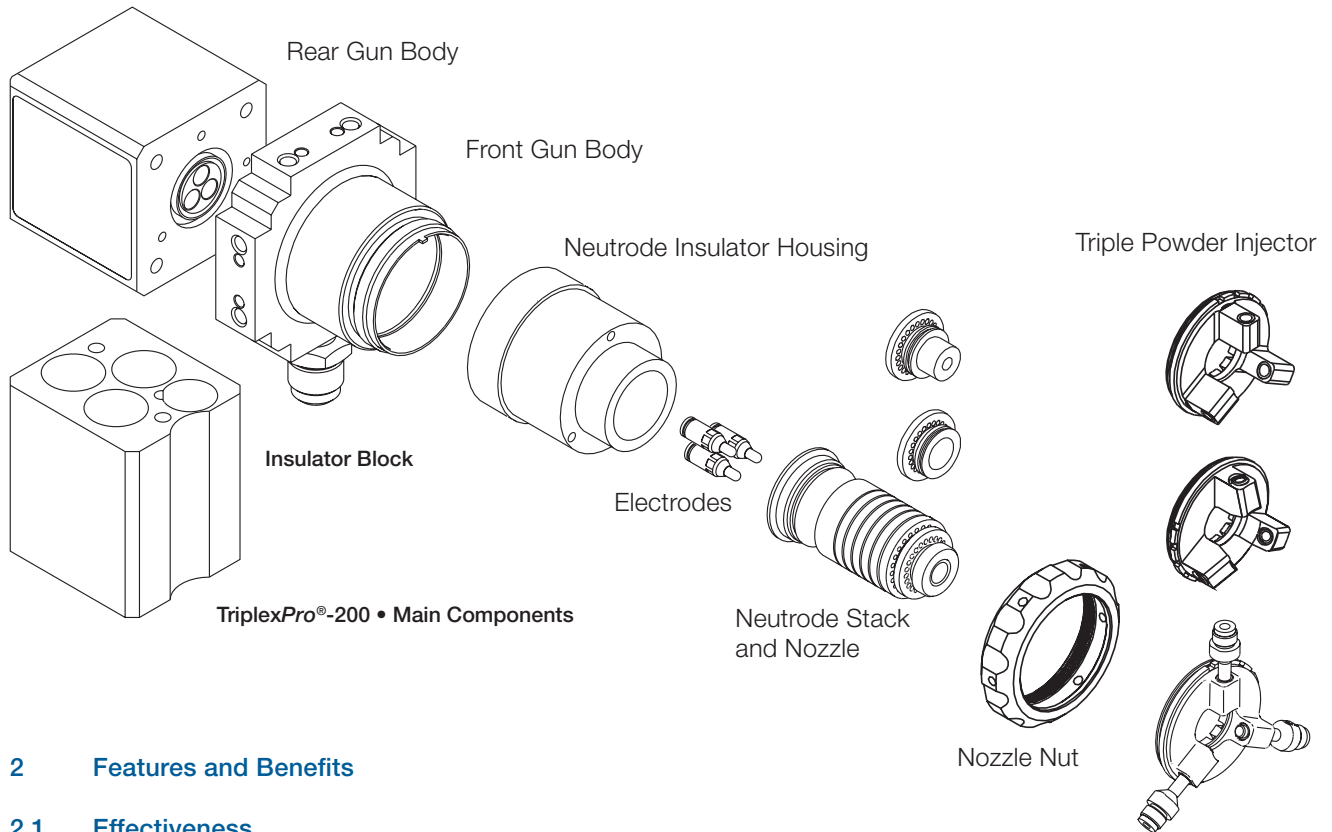

2 Features and Benefits

2.1 Effectiveness

- Designed for universal application use
- Produces the widest range of quality air plasma coatings possible
- Enhanced flexibility with included standard nozzles
- Plasma arc is stable over a wide range of gas flows, gas mixtures and pressures
- Small size permits coating of many part configurations, including some internal bores

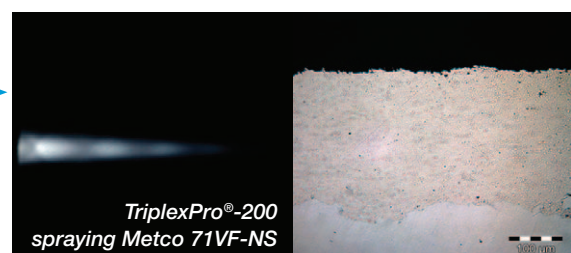
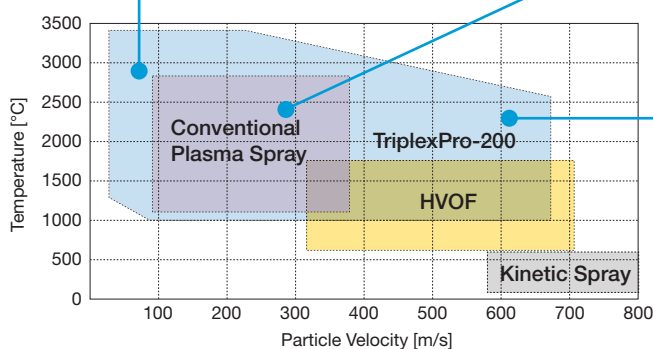
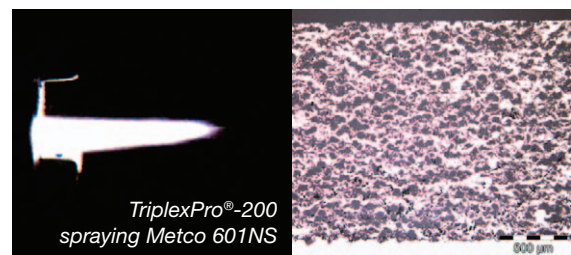
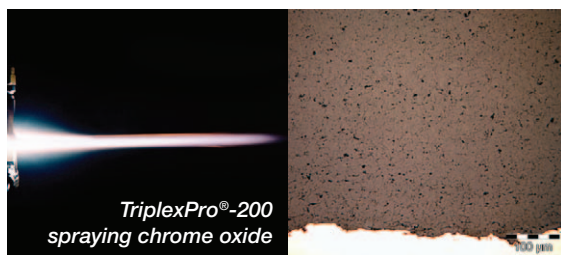

TriplexPro®-200's wide application range

2.2 Efficiency

- High throughput saves powder, energy and time
- Power divided over three individual arcs for more efficient heat transfer into the plasma plume
- Arcs are maintained at a fixed length for constant voltage and unprecedented stability
- Constant energy provides the ideal plasma state for all powder particles, improving deposit efficiency and application rates.
- Highly reproducible, TriplexPro-200 achieves the desired process window again and again.

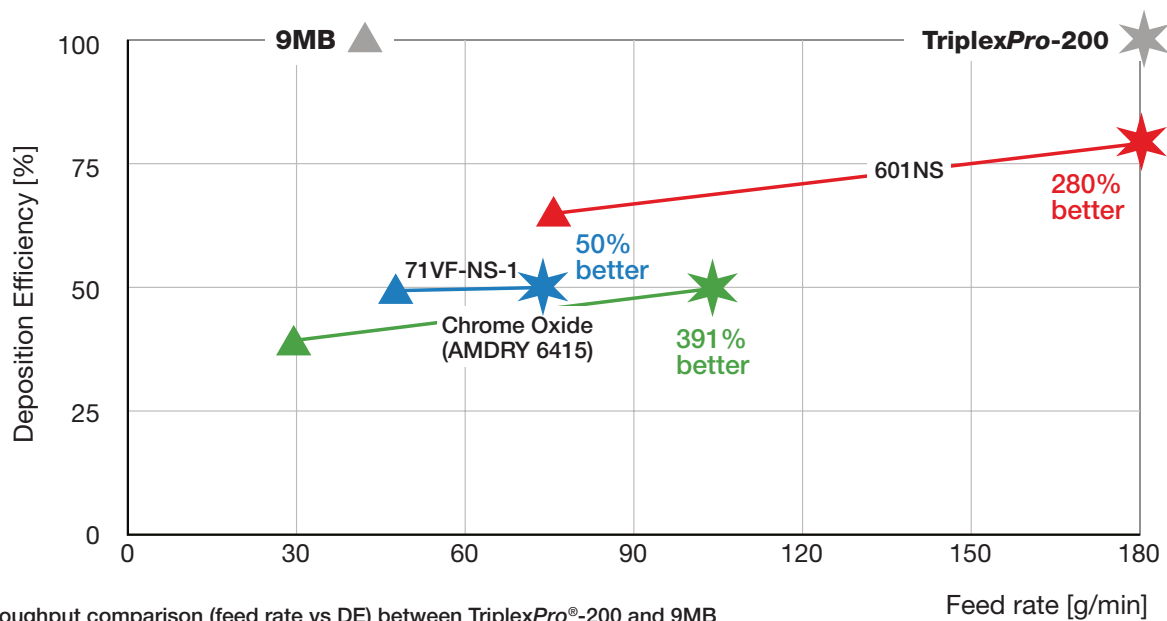

Throughput comparison (feed rate vs DE) between TriplexPro®-200 and 9MB

2.3 Economy

- Maintains constant performance over long periods with high coating consistency and no maintenance
- Runs continuously for up to 16 spray shifts
- Simple in-house service when required with quick exchange of gun consumables at designated service intervals

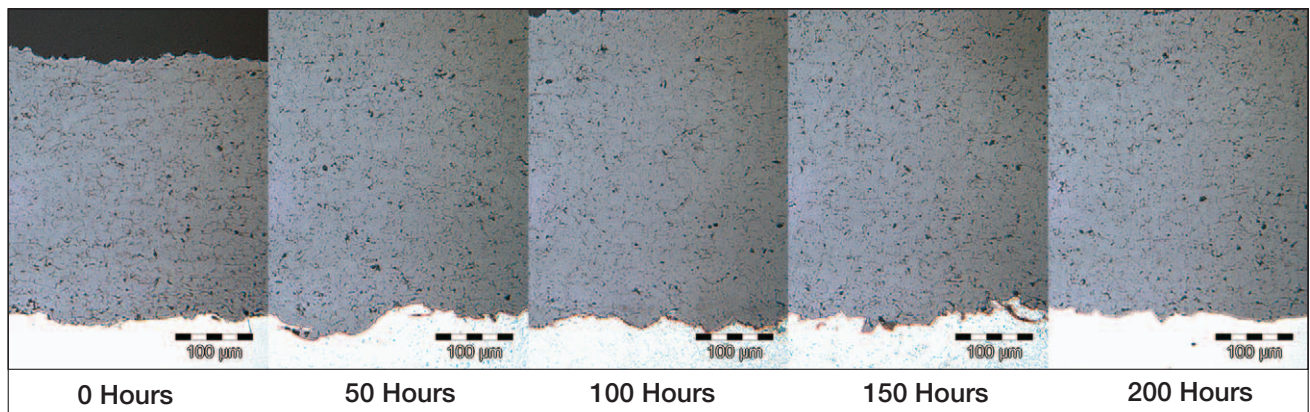

TriplexPro®-200 provides consistent coating results over long periods with no maintenance required, as seen from this 200 hour endurance test of chrome oxide sprayed at 62 kW. (AMDRIY 6420 with gun stopped and started before each test sample for a total of 62 ignitions).

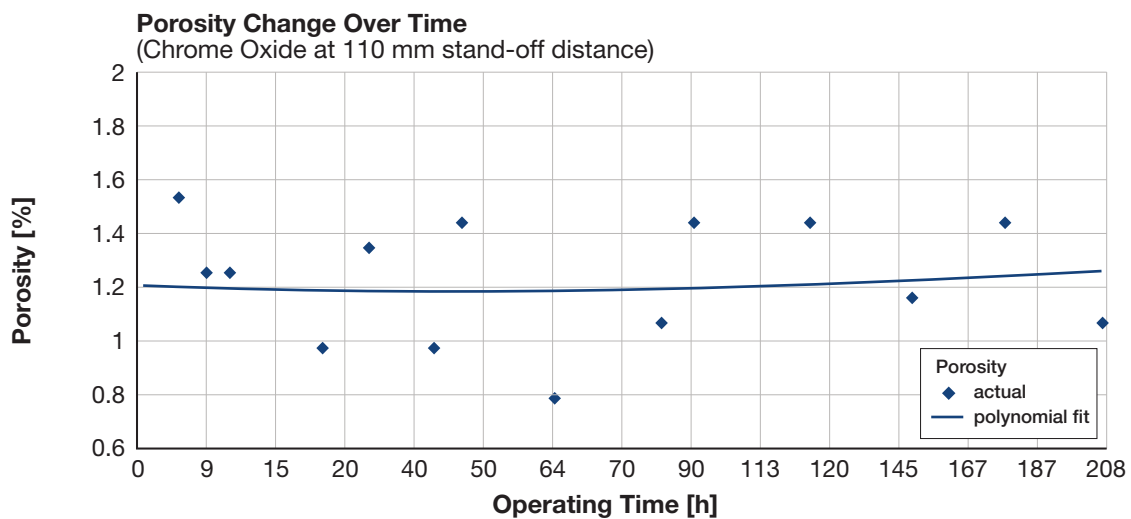
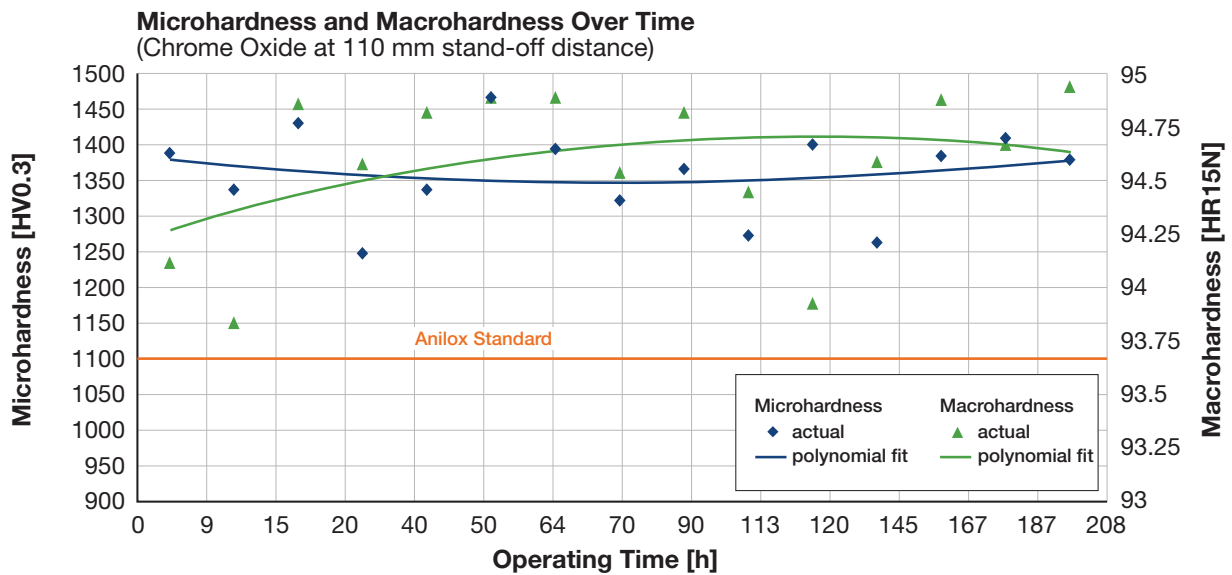
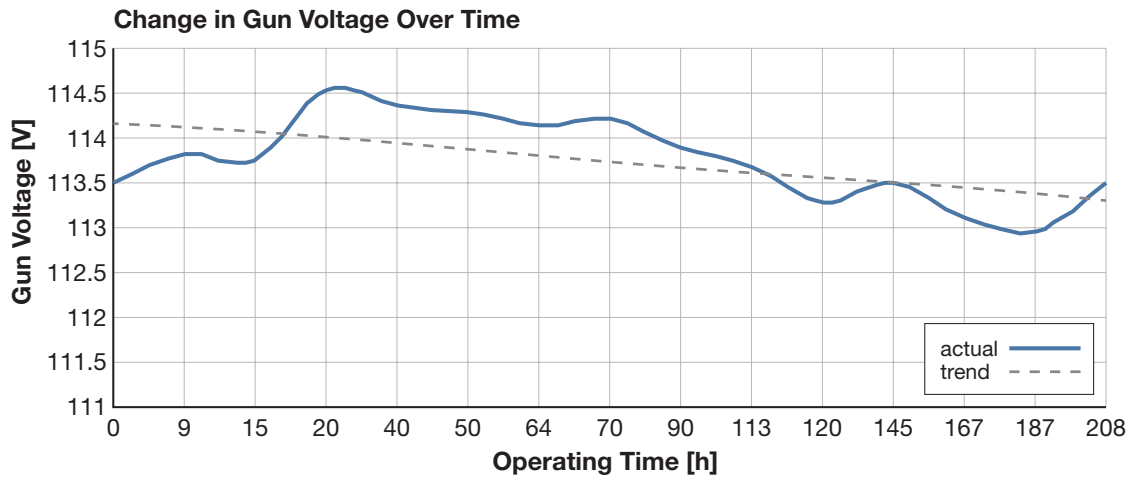

2.4 Environmentally Friendly

- No thoriated tungsten components, eliminates a waste disposal issue
- High thermal efficiency reduces power consumption requirements
- High throughput significantly reduces overspray waste
- Quiet operation, with noise pollution reduced using the standard nozzles. In the high energy configuration to spray carbide materials, noise is lower than HVOF spray guns producing comparable coatings.
- Excellent coatings can be produced with argon-only parameters, reducing the need to use expensive helium gas

3 Accessories and Options

Sulzer Metco offers a choice of hoses and cables in different lengths, powder injectors of various bore sizes and nozzles to be used with specific spray powders and to achieve a wide variety of plume enthalpies. For a complete list of optional parts and spare parts, please refer to the parts list section of the instruction manual.

Customers can choose from Sulzer Metco's extensive portfolio of thermal spray materials suitable for the plasma spray process. These include a variety of ceramics, alloys, superalloys, blends and self-fluxing materials to meet a wide range of surfacing needs.

3.1 Air Jets

Two types of air jets are available as options:

Cooling Nozzle Assembly - Designed to cool the substrate during the coating process.

Silvent Air Curtain Assembly - Attaches to the Cooling Nozzle Assembly to aid in the removal of overspray dust and reduce the potential inclusion of unmelted particles in the coating.

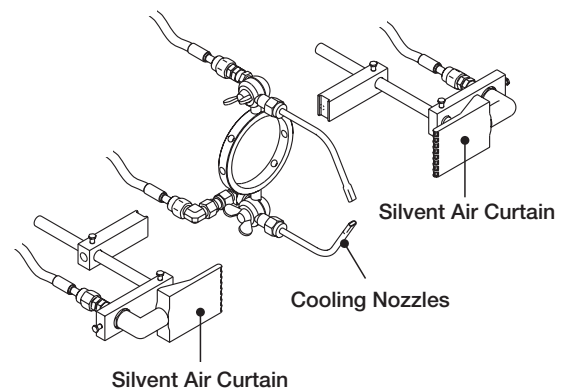

4 Technical Data

4.1 Dimensions

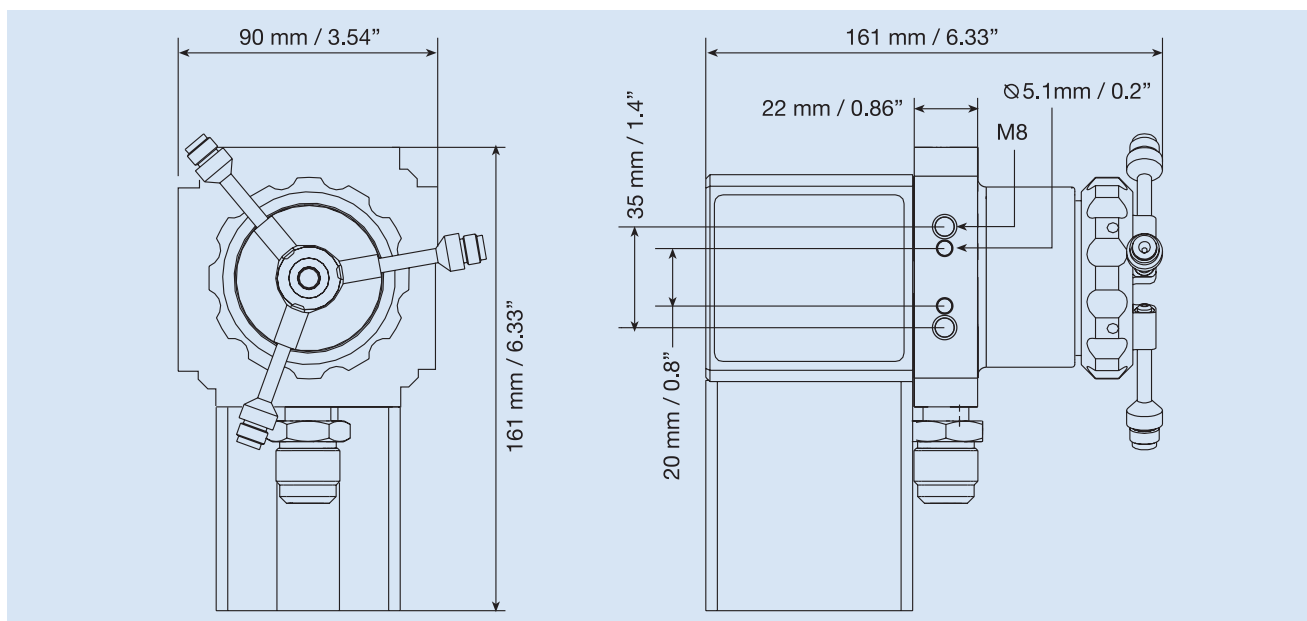

4.2 Specifications

Power Rating					
Maximum power – 100% duty cycle					
Standard operation		65		kW	
High velocity operation ¹		100		kW	
Maximum voltage					
Standard operation		132		V	
High velocity operation ¹		200		V	
Powder Feed					
Number of powder ports		3			
Number of radial detents		5			
Radial angles		0, 20, 40, 60, 80		degrees	
Gas Quality					
Argon – Ar					
Minimum requirements		99.95		%	
European standard		99.998		%	
Helium – He					
Minimum requirements		99.995		%	
European standard		99.998		%	
Nitrogen – N ₂					
Minimum requirements		99.7		%	
European standard		99.996		%	
Cooling Water Requirements					
Inlet temperature	max	18	°C	65	°F
Inlet pressure		13.8 – 17	bar	200 – 250	psi
Flow	min	18	l/min	4.75	gal/min
Total hardness		0.5	Grade F		
		0.35	Grade E		
		0.28	Grade D		
Conductivity	max	5	µS		
Dissolved oxygen	max	10	ppm		
Weight					
Without cooling jets, hoses and cables		2.6	kg	5.7	lb
Compatibility					
Controllers ²		MultiCoat®, UniCoat™			
Powder feeder		9MP-CL-20, Single/Twin 120-A, Single 220-A			
Power supply		TriStar IPS™-500/200			

¹ Life of consumable components is reduced using high velocity parameters

² Equipped with 200 NLPM Argon, 200 NLPM Helium and 50 NLPM Nitrogen capability. Existing MultiCoat and UniCoat systems can be field upgraded.

TriplexPro®-200 is protected under U.S. Patents 5225652, 5406046 and 7030336 with additional patents pending.

www.sulzermetco.com • info@sulzermetco.com			The Secret of Staying Ahead		
Sulzer Metco (US) Inc. 1101 Prospect Avenue Westbury NY 11590 USA Tel. +1 516 334 1300 Fax +1 516 338 2414	Sulzer Metco (Japan) Ltd. 4-2 Hikawadai 3-Chome, Nerima-ku, Tokyo 179-0084 Japan Tel. +81 359 203 302 Fax +81 359 203 512	Sulzer Metco Europe GmbH Am Eisernen Steg 18 D-65795 Hattersheim Germany Tel. +49 6190 8090 Fax +49 6190 3009	Sulzer Metco AG (Switzerland) Rigackerstrasse 16 CH-5610 Wohlen Switzerland Tel. +41 56 618 81 81 Fax +41 56 618 81 01	Sulzer Metco (Singapore) Pte. Ltd. 2 Loyang Lane # 06-02 Singapore 508913 Tel. +65 6545 0870 Fax +65 6545 0816	

Information is subject to change without prior notice